

# SCAN16512A

## Low Voltage Universal 16-bit IEEE 1149.1 Bus Transceiver with TRI-STATE Outputs

### General Description

The SCAN16512A is a high speed, low-power universal bus transceiver featuring data inputs organized into two 8-bit bytes with output enable and latch enable control signals. This function is configurable as a D-type Latch or Flip-Flop, and can operate in transparent, latched, or clocked mode. This device is compliant with IEEE 1149.1 Standard Test Access Port and Boundary Scan Architecture with the incorporation of the defined boundary-scan test logic and test access port consisting of Test Data Input (TDI), Test Data Out (TDO), Test Mode Select (TMS), Test Clock (TCK), and Test Reset (TRST).

### Features

- IEEE 1149.1 (JTAG) Compliant
- 2.7V to 3.6V  $V_{CC}$  Operation
- TRI-STATE outputs for bus-oriented applications
- Dual byte-wide data for bus applications
- Power down high Impedance inputs and outputs
- Optional Bus Hold on data inputs eliminates the need for external pullup/pulldown resistors (SCANH16512A, SCANH162512A versions)
- Optional  $25\Omega$  series resistors in outputs to minimize noise and eliminate termination resistors (SCAN162512A, SCANH162512A versions)
- Supports live insertion/withdrawal
- Includes CLAMP and HIGHZ instructions

### Block Diagram

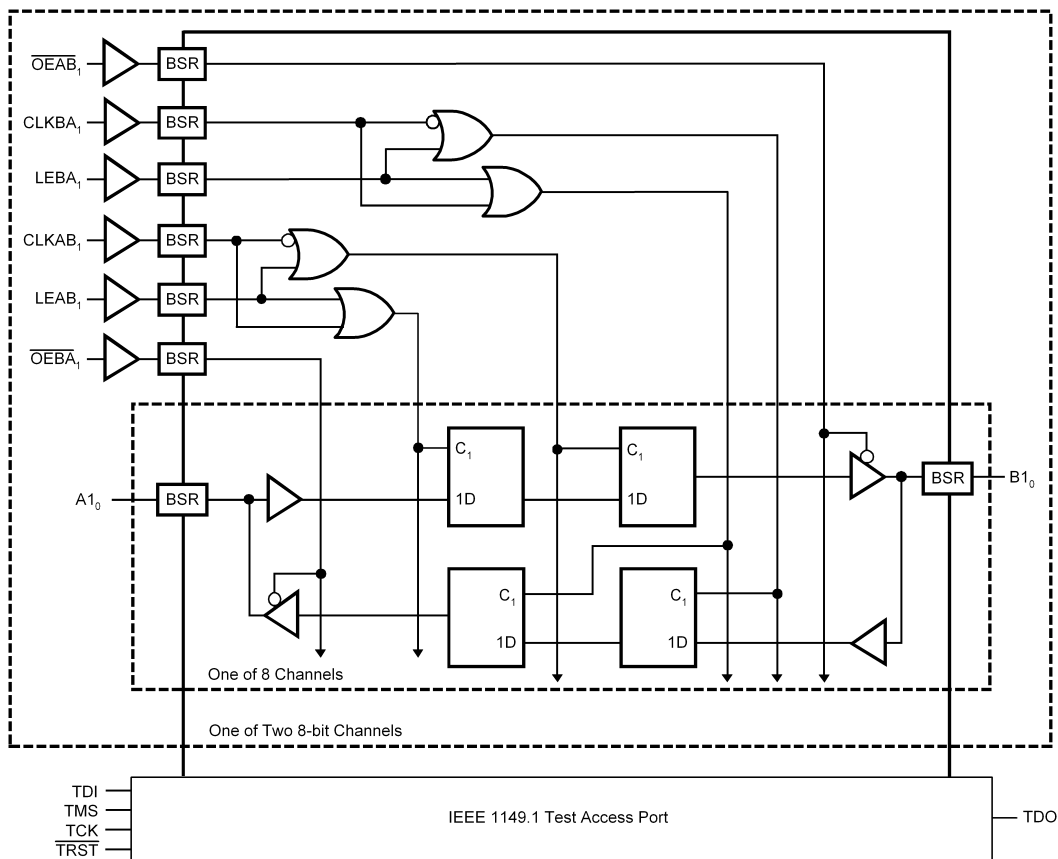

20075302

## Pin Descriptions

Pin Name	Description
A1 <sub>0</sub> -A1 <sub>7</sub> , A2 <sub>0</sub> -A2 <sub>7</sub>	Normal-function A-bus I/O ports. See function table for normal-mode logic.
B1 <sub>0</sub> -B1 <sub>7</sub> , B2 <sub>0</sub> -B2 <sub>7</sub>	Normal-function B-bus I/O ports. See function table for normal-mode logic.
CLKAB <sub>1</sub> , CLKBA <sub>1</sub> , CLKAB <sub>2</sub> , CLKBA <sub>2</sub>	Normal-function clock inputs. See function table for normal-mode logic.
GND	Ground
V <sub>CC</sub>	Supply Voltage
LEAB <sub>1</sub> , LEBA <sub>1</sub> , LEAB <sub>2</sub> , LEBA <sub>2</sub>	Normal-function latch enables. See function table for normal-mode logic.
$\overline{\text{OEAB}}_1$ , $\overline{\text{OEBA}}_1$ , $\overline{\text{OEAB}}_2$ , $\overline{\text{OEBA}}_2$	Normal-function output enables. See function table for normal-mode logic.
TDO	The Test Data Output to support IEEE Std 1149.1-1990. TDO is the serial output for shifting data through the instruction register or selected data register.
TMS	The Test Mode Select input to support IEEE Std 1149.1-1990. TMS directs the device through its TAP controller states. An internal pull-up forces TMS high if left unconnected.
TCK	The Test Clock input to support IEEE Std 1149.1-1990. Test operations of the device are synchronous to TCK. Data is captured on the rising edge of TCK and outputs change on the falling edge of TCK.
TDI	The Test Data Input to support IEEE Std 1149.1-1990. TDI is the serial input to shift data through the instruction register or the selected data register. An internal pull-up resistor forces TDI high if left unconnected.
$\overline{\text{TRST}}$	The Test Reset Input to support IEEE Std 1149.1-1990. TRST is the asynchronous reset pin which will force the TAP controller to its initialization state when active. An internal pullup resistor forces $\overline{\text{TRST}}$ high if left unconnected.

## BGA Pinout

	1	2	3	4	5	6	7	8
A	A1 <sub>0</sub>	A1 <sub>2</sub>	A1 <sub>4</sub>	A1 <sub>6</sub>	A2 <sub>0</sub>	A2 <sub>2</sub>	A2 <sub>4</sub>	A2 <sub>6</sub>
B	A1 <sub>1</sub>	A1 <sub>3</sub>	A1 <sub>5</sub>	A1 <sub>7</sub>	A2 <sub>1</sub>	A2 <sub>3</sub>	A2 <sub>5</sub>	A2 <sub>7</sub>
C	$\overline{\text{TRST}}$	CLKAB <sub>1</sub>	LEAB <sub>1</sub>	$\overline{\text{OEAB}}_1$	GND	CLKAB <sub>2</sub>	LEAB <sub>2</sub>	$\overline{\text{OEAB}}_2$
D	TMS	GND	V <sub>CC</sub>	GND	V <sub>CC</sub>	GND	TDI	TDO
E	TCK	GND	V <sub>CC</sub>	V <sub>CC</sub>	GND	GND	N/C	V <sub>CC</sub>
F	CLKBA <sub>1</sub>	LEBA <sub>1</sub>	$\overline{\text{OEBA}}_1$	GND	N/C	CLKBA <sub>2</sub>	LEBA <sub>2</sub>	$\overline{\text{OEBA}}_2$
G	B1 <sub>1</sub>	B1 <sub>3</sub>	B1 <sub>5</sub>	B1 <sub>7</sub>	B2 <sub>1</sub>	B2 <sub>3</sub>	B2 <sub>5</sub>	B2 <sub>7</sub>
H	B1 <sub>0</sub>	B1 <sub>2</sub>	B1 <sub>4</sub>	B1 <sub>6</sub>	B2 <sub>0</sub>	B2 <sub>2</sub>	B2 <sub>4</sub>	B2 <sub>6</sub>

## Connection Diagram

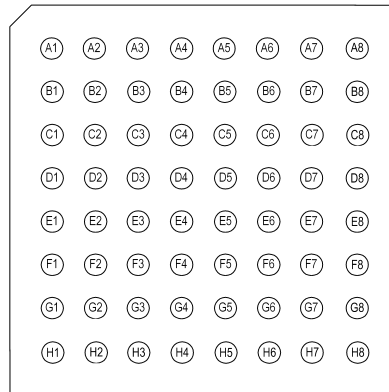

20075303

**Top View**  
See NS Package Number SLC64A

## Truth Table

**Function Table (Note 1)**

Inputs				Outputs
$\overline{OEAB}$	LEAB	CLKAB	A	B
L	L	L	X	$B_0$ (Note 2)
L	L	↑	L	L
L	L	↑	H	H
L	H	X	L	L
L	H	X	H	H
H	X	X	X	Z

H = HIGH Voltage Level

L = LOW Voltage Level

X = Immaterial (HIGH or LOW, inputs may not float)

Z = High Impedance

**Note 1:** A-to-B data flow is shown. B-to-A data flow is similar, but uses  $\overline{OEBA}$ , LEBA, and CLKBA.

**Note 2:** Output level before the indicated steady-state input conditions were established.

## Functional Description

In the normal mode, these devices are 16-bit universal bus transceivers that combine D-type latches and D-type flip-flops to allow data flow in transparent, latched, or clocked modes. They can be used as two 8-bit transceivers, or as one 16-bit transceiver. The test circuitry can be activated by the TAP to take snapshot samples of the data appearing at the device pins or to perform a self test on the boundary-test cells. Activating the TAP may affect the normal functional operation of the universal bus transceivers. When the TAP is activated, the test circuitry performs boundary-scan test operations according to the protocol described in IEEE Std 1149.1-1990.

Data flow in each direction is controlled by output-enable ( $\overline{OEAB}$  and  $\overline{OEBA}$ ), latch-enable (LEAB and LEBA), and clock (CLKAB and CLKBA) inputs. For A-to-B data flow, the

devices operate in the transparent mode when LEAB is high. When LEAB is low, the A data is latched while CLKAB is held at a static low or high logic level. Otherwise, if LEAB is low, A data is stored on a low-to-high transition of CLKAB. When  $\overline{OEAB}$  is LOW, the B outputs are active. When  $\overline{OEAB}$  is HIGH, the B outputs are in the high-impedance state. B-to-A data flow is similar to A-to-B data flow but uses the  $\overline{OEBA}$ , LEBA, and CLKBA inputs.

Five dedicated test pins are used to observe and control the operation of the test circuitry: test data input (TDI), test data output (TDO), test mode select (TMS), test clock (TCK), and test reset ( $\overline{TRST}$ ). All testing and scan operations are synchronized to the TAP interface.

For details about the sequence of boundary scan cells in the SCAN16512A, please refer to the BSDL (Boundary Scan Description Language) file available on our website.

**Absolute Maximum Ratings** (Note 3)

Supply Voltage ( $V_{CC}$ )	-0.5V to +4.6V
DC Input Diode Current ( $I_{IK}$ )	
$V_I = -0.5V$	-50 mA
DC Output Diode Current ( $I_{OK}$ )	
$V_O = -0.5V$	-50 mA
DC Input Voltage ( $V_I$ )	-0.5V to 4.6V
DC Output Voltage ( $V_O$ )	-0.5V to 4.6V
DC Output Source/Sink Current ( $I_O$ )	$\pm 50$ mA
DC $V_{CC}$ or Ground Current	
Per Supply Pin	$\pm 100$ mA
Junction Temperature	+150°C
Storage Temperature	-65°C to +150°C
Lead Temperature (Solder, 4sec)	
64L BGA	220 °C
Thermal Resistance	
BGA $\theta_{JA}$	62°C/W

Package Derating

16.1mW/°C above

25°C

ESD (Min)

2000V

**Recommended Operating Conditions**

Supply Voltage ( $V_{CC}$ )	
SCAN16512A	2.7V to 3.6V
Input Voltage ( $V_I$ )	0V to 3.6V
Output Voltage ( $V_O$ )	0V to 3.6V
Operating Temperature ( $T_A$ )	
Industrial	-40°C to +85°C

**Note 3:** Absolute maximum ratings are those values beyond which damage to the device may occur. The databook specifications should be met, without exception, to ensure that the system design is reliable over its power supply, temperature, and output/input loading variables. National does not recommend operation of SCAN circuits outside databook specifications.

**DC Electrical Characteristics**

Symbol	Parameter	$V_{CC}$ (V)	Industrial		Units	Conditions
			$T_A = -40^\circ\text{C to } +85^\circ\text{C}$			
			Min	Max		
$V_{IH}$	Minimum High Input Voltage	2.7	2.0		V	$V_{OUT} = 0.1V$ or $V_{CC} - 0.1V$
		3.6	2.0			
$V_{IL}$	Maximum Low Input Voltage	2.7		0.8	V	$V_{OUT} = 0.1V$ or $V_{CC} - 0.1V$
		3.6		0.8		
$V_{OH}$	Minimum High Output Voltage All Outputs, All Options	2.7	2.5		V	$I_{OUT} = -100$ $\mu\text{A}$
		3.6	3.4			
		2.7	2.2			
	Minimum High Output Voltage TDO Outputs, All Options	3.0	2.2		V	$V_{IN} = V_{IL}$ or $V_{IH}$ $I_{OH} = -12\text{mA}$
	Minimum High Output Voltage A and B Ports: SCAN16512A and SCANH16512A options	2.7	2.2		V	$V_{IN} = V_{IL}$ or $V_{IH}$ $I_{OH} = -12\text{mA}$
		3.0	2.2			
	Minimum High Output Voltage A and B Ports: SCAN162512A and SCANH162512A options (25 $\Omega$ series resistor options)	2.7	2.2		V	$V_{IN} = V_{IL}$ or $V_{IH}$ $I_{OH} = -4\text{mA}$
3.0		2.2				
$V_{OL}$	Maximum Low Output Voltage All Outputs, All Options	2.7		0.2	V	$I_{OUT} = 100$ $\mu\text{A}$
		3.6		0.2		

## DC Electrical Characteristics (Continued)

Symbol	Parameter	V <sub>CC</sub> (V)	Industrial		Units	Conditions
			T <sub>A</sub> = -40°C to +85°C			
			Min	Max		
	Maximum Low Output Voltage TDO Outputs, All Options	2.7		0.4	V	V <sub>IN</sub> = V <sub>IL</sub> or V <sub>IH</sub> , I <sub>OL</sub> = 12mA
		3.0		0.55	V	V <sub>IN</sub> = V <sub>IL</sub> or V <sub>IH</sub> , I <sub>OL</sub> = 24mA
	Maximum Low Output Voltage A and B Ports: SCAN16512A and SCANH16512A Options	2.7		0.4	V	V <sub>IN</sub> = V <sub>IL</sub> or V <sub>IH</sub> , I <sub>OL</sub> = 12mA
		3.0		0.55	V	V <sub>IN</sub> = V <sub>IL</sub> or V <sub>IH</sub> , I <sub>OL</sub> = 24mA
	Maximum Low Output Voltage A and B Ports: SCAN162512A and SCANH162512A Options (25Ω series resistor options)	2.7		0.4	V	V <sub>IN</sub> = V <sub>IL</sub> or V <sub>IH</sub> , I <sub>OL</sub> = 4mA
		3.0		0.6	V	V <sub>IN</sub> = V <sub>IL</sub> or V <sub>IH</sub> , I <sub>OL</sub> = 12mA
I <sub>IN</sub>	Maximum Input Leakage Current	3.6		±5.0	μA	V <sub>I</sub> = V <sub>CC</sub> , GND
I <sub>ILR</sub>	Input Low Current	3.6	-20	-250	μA	V <sub>IN</sub> = GND
I <sub>OZ</sub>	Maximum I/O Leakage Current	3.6		±10.0	μA	V <sub>I</sub> (OE) = V <sub>IL</sub> , V <sub>IH</sub> V <sub>I</sub> = V <sub>CC</sub> , GND V <sub>O</sub> = V <sub>CC</sub> , GND
I <sub>I(HOLD)</sub>	Bus Hold Input Minimum Drive Hold Current (Note 4)	2.7	±35		μA	V <sub>I</sub> = 0.8V or 2.0V
		3.6		±500		V <sub>I</sub> = 0 to 3.6V
V <sub>IKL</sub>	Input Clamp Diode Voltage	2.7		-1.5	V	I <sub>IN</sub> = -18mA
I <sub>OFF</sub>	Power-off Leakage Current	0.0		±10.0	μA	V <sub>O</sub> = V <sub>CC</sub> , GND
I <sub>CC</sub>	Maximum Quiescent Supply Current	3.6		20	μA	
I <sub>CCt</sub>	Maximum I <sub>CC</sub> Per Input	3.6		0.5	mA	V <sub>I</sub> = V <sub>CC</sub> -0.6V

**Note 4:** Applies to devices with Bus Hold feature only.

## Noise Specifications

Applies to SCAN16512A and SCANH16512A options,  $C_L = 30\text{pF}$ ,  $R_L = 500\Omega$  to GND

Symbol	Parameter	$V_{CC}$ (V)	Industrial	Units
			$T_A = 25^\circ\text{C}$	
			Typical Limits	
$V_{OLP}$	Quiet Output Maximum Dynamic VOL (Note 5)	3.3	1.2	V
$V_{OLV}$	Quiet Output Minimum Dynamic VOL (Note 5)	3.3	-1.5	V
$V_{OHP}$	Quiet Output Maximum Dynamic VOH (Note 6)	3.3	$VOH + 0.9$	V
$V_{OHV}$	Quiet Output Minimum Dynamic VOH (Note 6)	3.3	$VOH - 1.5$	V

## Noise Specifications

Applies to SCAN162512A and SCANH162512A options,  $C_L = 30\text{pF}$ ,  $R_L = 500\Omega$  to GND

Symbol	Parameter	$V_{CC}$ (V)	Industrial	Units
			$T_A = 25^\circ\text{C}$	
			Typical Limits	
$V_{OLP}$	Quiet Output Maximum Dynamic VOL (Note 5)	3.3	0.5	V
$V_{OLV}$	Quiet Output Minimum Dynamic VOL (Note 5)	3.3	-0.4	V
$V_{OHP}$	Quiet Output Maximum Dynamic VOH(Note 6)	3.3	$VOH + 0.5$	V
$V_{OHV}$	Quiet Output Minimum Dynamic VOH (Note 6)	3.3	$VOH - 0.5$	V

**Note 5:** Maximum number of outputs is defined as n. (n-1) outputs are switched LOW while the quiet output is monitored in a LOW (VOL) state. Also, (n-1) outputs are switched HIGH while the quiet output is monitored in a LOW (VOL) state.

**Note 6:** Maximum number of outputs is defined as n. (n-1) outputs are switched LOW while the quiet output is monitored in a HIGH (VOH) state. Also, (n-1) outputs are switched HIGH while the quiet output is monitored in a HIGH (VOH) state.

## AC Electrical Characteristics

Normal Operation, over recommended operating supply voltage and temperature ranges unless otherwise specified.

Symbol	Parameter	SCAN16512A, SCANH16512A		Units
		$T_A = -40^\circ\text{C to } +85^\circ\text{C}$ $C_L = 30\text{ pF}$ $R_L = 500\Omega\text{ to GND}$		
		Min	Max	
$t_{PLH}$ , $t_{PHL}$	Propagation Delay A to B, B to A		5.5	ns
$t_{PLH}$ , $t_{PHL}$	Propagation Delay CLKAB to B, CLKBA to A		6.0	ns
$t_{PLH}$ , $t_{PHL}$	Propagation Delay LEAB to B, LEBA to A		6.0	ns
$t_{PLZ}$ , $t_{PHZ}$	Disable Time, $\overline{OEAB}$ to B, $\overline{OEBA}$ to A		7.5	ns
$t_{PZL}$ , $t_{PZH}$	Enable Time, $\overline{OEAB}$ to B, $\overline{OEBA}$ to A		7.5	ns

## AC Electrical Characteristics

Normal Operation, over recommended operating supply voltage and temperature ranges unless otherwise specified.

Symbol	Parameter	SCAN162512A		Units
		$T_A = -40^\circ\text{C to } +85^\circ\text{C}$ $C_L = 30\text{ pF}$ $R_L = 500\Omega\text{ to GND}$		
		Min	Max	
$t_{PLH}$ , $t_{PHL}$	Propagation Delay A to B, B to A		6.0	ns
$t_{PLH}$ , $t_{PHL}$	Propagation Delay CLKAB to B, CLKBA to A		6.5	ns
$t_{PLH}$ , $t_{PHL}$	Propagation Delay LEAB to B, LEBA to A		6.5	ns
$t_{PLZ}$ , $t_{PHZ}$	Disable Time, $\overline{OEAB}$ to B, $\overline{OEBA}$ to A		8.0	ns
$t_{PZL}$ , $t_{PZH}$	Enable Time, $\overline{OEAB}$ to B, $\overline{OEBA}$ to A		8.0	ns

## AC Electrical Characteristics

Normal Operation, over recommended operating supply voltage and temperature ranges unless otherwise specified.

Symbol	Parameter	SCANH162512A		Units
		$T_A = -40^\circ\text{C to } +85^\circ\text{C}$ $C_L = 30\text{ pF}$ $R_L = 500\Omega\text{ to GND}$		
		Min	Max	
$t_{PLH}$ , $t_{PHL}$	Propagation Delay A to B, B to A		6.0	ns
$t_{PLH}$ , $t_{PHL}$	Propagation Delay CLKAB to B, CLKBA to A		6.5	ns
$t_{PLH}$ , $t_{PHL}$	Propagation Delay LEAB to B, LEBA to A		6.5	ns
$t_{PLZ}$ , $t_{PHZ}$	Disable Time, $\overline{OEAB}$ to B, $\overline{OEBA}$ to A		8.0	ns
$t_{PZL}$ , $t_{PZH}$	Enable Time, $\overline{OEAB}$ to B, $\overline{OEBA}$ to A		8.0	ns

## AC Operating Requirements

Normal Operation, over recommended operating supply voltage and temperature ranges unless otherwise specified

Symbol	Parameter	All Options		Units
		$T_A = -40^\circ\text{C to } +85^\circ\text{C}$ $C_L = 30\text{ pF}$ , $R_L = 500\Omega\text{ to GND}$		
		Guaranteed Minimum		
$t_S$	Setup Time, A to CLKAB or B to CLKBA		1.5	ns
$t_H$	Hold Time, A to CLKAB or B to CLKBA		2.0	ns
$t_S$	Setup Time, A to LEAB or B to LEBA		1.5	ns
$t_H$	Hold Time, A to LEAB or B to LEBA		2.5	ns
$t_W$	Pulse Width, CLKAB or CLKBA, high or low		2.0	ns
$t_W$	Pulse Width, LEAB or LEBA high		2.0	ns
$f_{max}$	Maximum CLKAB or CLKBA Clock Frequency		250	MHz

## AC Operating Requirements

can Test Operation, over recommended operating supply voltage and temperature ranges unless otherwise specified

Symbol	Parameter	All Options		Units
		$T_A = -40^\circ\text{C to } +85^\circ\text{C}$ $C_L = 30\text{ pF}$ , $R_L = 500\Omega\text{ to GND}$		
		Guaranteed Minimum		
$t_S$	Setup Time, H or L, TMS to TCK		2.0	ns
$t_H$	Hold Time, H or L, TCK to TMS		1.0	ns
$t_S$	Setup Time, H or L, TDI to TCK		1.0	ns
$t_H$	Hold Time, H or L, TCK to TDI		2.0	ns
$t_W$	Pulse Width TCK High or Low		10	ns
$t_W$	Pulse Width $\overline{TRST}$ , Low		2.5	ns
$f_{max}$	Maximum TCK Clock Frequency		25	MHz
$t_{REC}$	Recovery Time, $\overline{TRST}$ to TCK		2.0	ns



# AC Loading and Waveforms

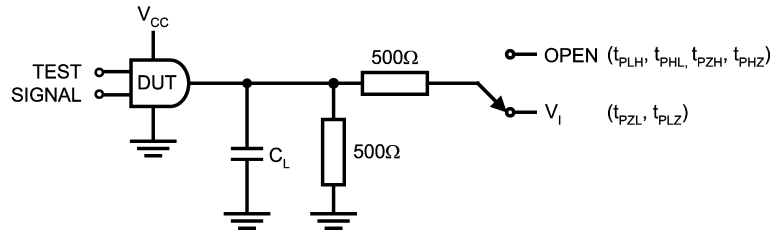

20075314

FIGURE 1. AC Test Circuit ( $C_L$  includes probe and jig capacitance)

$V_I$	$C_L$
$V_{CC} * 2$	30pF

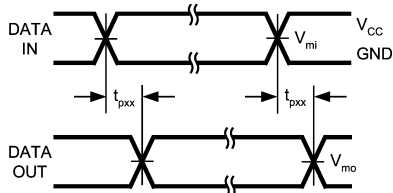

20075310

Waveform for Inverting and Non-inverting Functions

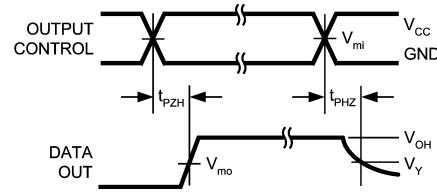

20075311

Tristate Output High Enable and Disable Times for Logic

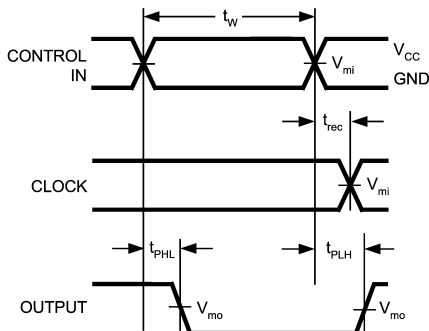

20075312

Propagation Delay, Pulse Width and  $t_{REC}$  Waveforms

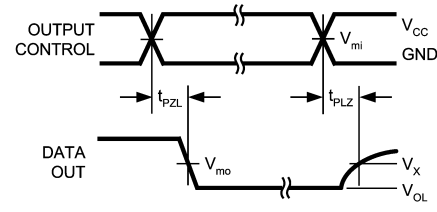

20075313

Tristate Output Low Enable and Disable Times for Logic

FIGURE 2. Timing Waveforms  
(Input Characteristics;  $f = 1\text{MHz}$ ,  $t_r = t_f = 2.5\text{ns}$ )

Symbol	$V_{CC}$
	2.7 - 3.6V
$V_{mi}$	1.5V
$V_{mo}$	1.5V
$V_X$	$V_{OL} + 0.3\text{V}$
$V_Y$	$V_{OH} - 0.3\text{V}$

## Capacitance and I/O Characteristics

Refer to National's website for IBIS models at <http://www.national.com/scan>

### Device ID Register

Ordering Code	Features	Device ID	Manufacturer & LSB
SCAN16512ASM	No bus hold, no series resistor	FC30	01F
SCANH16512ASM	With bus hold only	FC31	01F
SCAN162512ASM	With 25 $\Omega$ series resistors in outputs	FC32	01F
SCANH162512ASM	With 25 $\Omega$ series resistors and bus hold	FC33	01F

## Physical Dimensions inches (millimeters)

unless otherwise noted

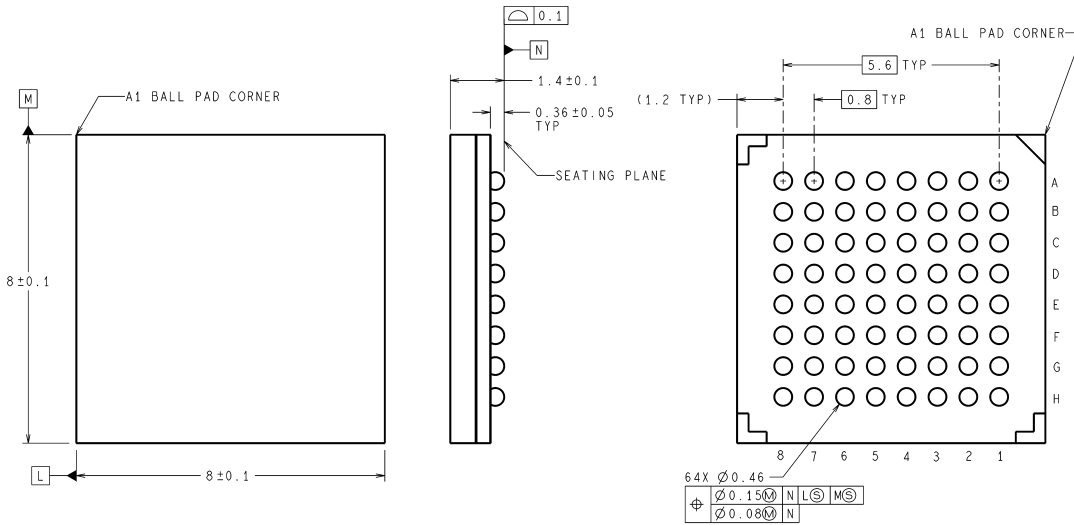

DIMENSIONS ARE IN MILLIMETERS

SLC64A (Rev C)

**64-Lead Ball Grid Array Package**  
**Order Number SCAN16512ASM,**  
**SCANH16512ASM, SCAN162512ASM, SCANH162512ASM**  
**NS Package Number SLC64A**

### LIFE SUPPORT POLICY

NATIONAL'S PRODUCTS ARE NOT AUTHORIZED FOR USE AS CRITICAL COMPONENTS IN LIFE SUPPORT DEVICES OR SYSTEMS WITHOUT THE EXPRESS WRITTEN APPROVAL OF THE PRESIDENT AND GENERAL COUNSEL OF NATIONAL SEMICONDUCTOR CORPORATION. As used herein:

1. Life support devices or systems are devices or systems which, (a) are intended for surgical implant into the body, or (b) support or sustain life, and whose failure to perform when properly used in accordance with instructions for use provided in the labeling, can be reasonably expected to result in a significant injury to the user.
2. A critical component is any component of a life support device or system whose failure to perform can be reasonably expected to cause the failure of the life support device or system, or to affect its safety or effectiveness.

### BANNED SUBSTANCE COMPLIANCE

National Semiconductor certifies that the products and packing materials meet the provisions of the Customer Products Stewardship Specification (CSP-9-111C2) and the Banned Substances and Materials of Interest Specification (CSP-9-111S2) and contain no "Banned Substances" as defined in CSP-9-111S2.



**National Semiconductor**  
**Americas Customer**  
**Support Center**  
 Email: [new.feedback@nsc.com](mailto:new.feedback@nsc.com)  
 Tel: 1-800-272-9959

**National Semiconductor**  
**Europe Customer Support Center**  
 Fax: +49 (0) 180-530 85 86  
 Email: [europe.support@nsc.com](mailto:europe.support@nsc.com)  
 Deutsch Tel: +49 (0) 69 9508 6208  
 English Tel: +44 (0) 870 24 0 2171  
 Français Tel: +33 (0) 1 41 91 8790

**National Semiconductor**  
**Asia Pacific Customer**  
**Support Center**  
 Email: [ap.support@nsc.com](mailto:ap.support@nsc.com)

**National Semiconductor**  
**Japan Customer Support Center**  
 Fax: 81-3-5639-7507  
 Email: [jpn.feedback@nsc.com](mailto:jpn.feedback@nsc.com)  
 Tel: 81-3-5639-7560

[www.national.com](http://www.national.com)